

# HENGE<sup>®</sup>

## *Product Sheet*

### *Model*

#### **ES - TABLE**

**STRUCTURE** Solidwood, thickness 20 mm with cover for legs in burnished brass with laser-cut pattern **TOP FINISH** Heat treated woods as our samples and Swamp Oak oil finish based on natural wax and water. Slabs in brass hand-burnished using traditional techniques. **LEGS FINISH** Heat treated woods as our samples and Swamp Oak oil finish based on natural wax and water. Cover in brass hand-burnished using traditional techniques.

---

## *Scheda Prodotto*

### *Modello*

#### **ES - TABLE**

**STRUTTURA** Legno listellare sp. 2 cm con carter per gambe in ottone con disegno fantasia taglio laser **FINITURA PIANO** Legni termotrattati nelle finiture a campionario e rovere di palude, finiti ad olio a base di cera naturale e acqua. Lastre in ottone brunito a mano secondo le tecniche tradizionali **FINITURA GAMBE** Legni termotrattati nelle finiture a campionario e rovere di palude, finiti ad olio a base di cera naturale e acqua. Carter in ottone brunito a mano secondo le tecniche tradizionali.

# ES - TABLE

*Design* Massimo Castagna

**Table . Tavolo 250x98x75h**

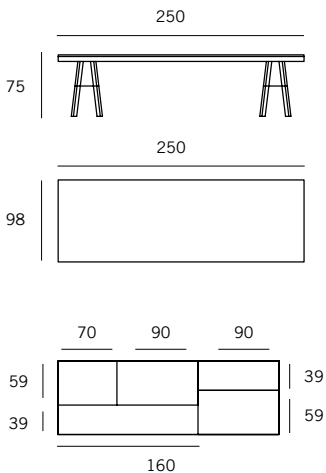

**Table . Tavolo 300x98x75**

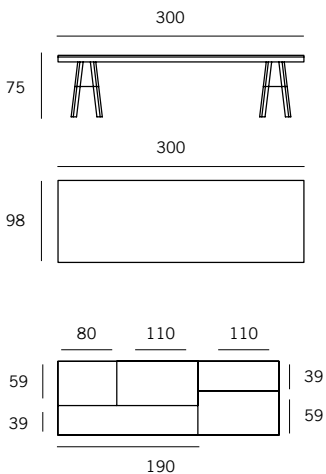

DIMENSIONS  
250 x 98 x 75 cm  
300 x 98 x 75 cm

DIMENSIONI  
250 x 98 x 75 cm  
300 x 98 x 75 cm